

@216 & @217

INS-P0216-PAC

ASSEMBLY INSTRUCTIONS



PARTS



Back (x1)



Seat (x1)

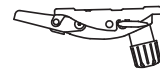

Mechanism (x1)



Arms (x2)

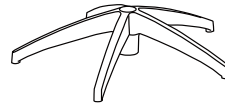

Base (x1)

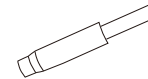

Cylinder (x1)



Casters (x5)

TOOLS



Allen Wrench (x1)
(attached to the
cylinder box)

HARDWARE



M8 bolts for the back (x3)



1/4" x 1" bolts for the mechanism (x4)



1/4" x 3/4" bolts for the arms (x8)

All hardware comes pre-attached in the back and/or seat.
Missing parts or hardware? Call 888.925.SEAT

STEP 1

Attach the casters and cylinder to the 5-star base.

1A. Firmly press the stems of 5 casters into the 5 holes in the base.

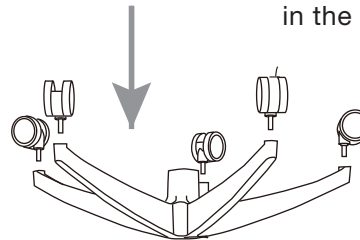

1B. Insert cylinder into the center hole.

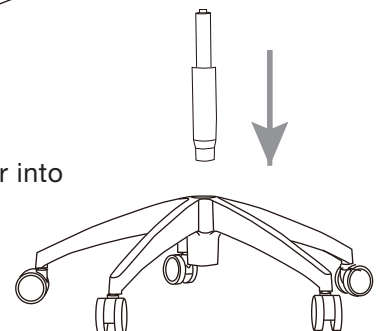

STEP 2

Attach the arms to the seat.

2A. Invert the seat, fabric side down, and remove the ¼" x ¾" bolts for the arms from the seat with the Allen wrench. There are 8 bolts total (4 per arm).

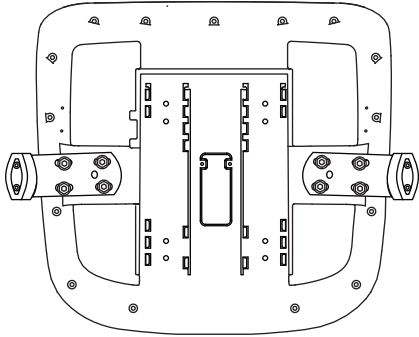

2B. Adjust the left and right arms to be symmetrical, then reattach the bolts to secure the arms.

STEP 3

Attach the mechanism to the seat.

3A. Using the Allen wrench, remove the ¼" x 1" bolts and that hold the mechanism. There are 4 bolts total.

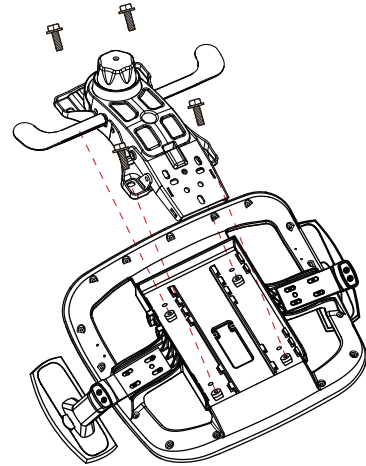

3B. Place the mechanism on the underside of the seat as shown, then reattach the bolts.

STEP 4

Attach the back to the seat.

4A. Using the Allen wrench, remove the 3 M8 bolts from the back.

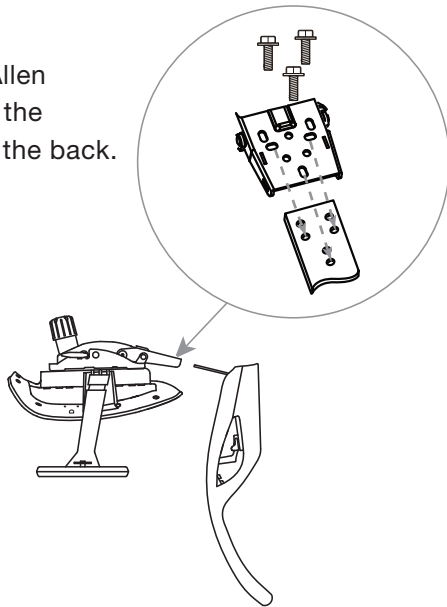

2B. Place the back plate under the seat as shown, aligning the holes. Using the Allen wrench, reattach the bolts from the top.

STEP 5

Join the back and seat with the cylinder and base.

Insert the assembled back/seat unit onto the cylinder, which was placed in the base in Step 1. Press down firmly to secure.

